

LifeSource™

Your source for a lifetime of health



Congratulations. You have purchased a LifeSource state-of-the-art blood pressure monitor, one of the most technologically advanced yet easy to use products available in the marketplace today. This LifeSource monitor is designed to make your daily regimen useful, and convenient.

Physicians agree that daily self-monitoring of blood pressure is an important way individuals can contribute to maintaining their cardiovascular health and preventing the serious consequences of hypertension left undiagnosed and untreated.

LifeSource has been manufacturing quality healthcare products for more than 20 years. Rest assured that we are committed to providing you and your family with monitoring devices specifically designed for high accuracy and ease of use. LifeSource—your source for a lifetime of health.

TABLE OF CONTENTS



WHAT DISPLAY SYMBOLS MEAN 3
MONITOR COMPONENTS 4
HOW 779 WORKS 5

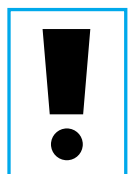

BEFORE YOU START 5
SELECTING THE CORRECT CUFF 6

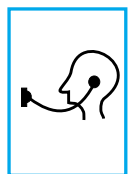

TAKING YOUR BLOOD PRESSURE 7 — 10
ABOUT MEMORY 10



CHECK/ADJUST EXHAUST VELOCITY 11 — 12



ABOUT BLOOD PRESSURE 13 — 15
BLOOD PRESSURE RECORD 16









IMPORTANT INFORMATION 17
SPECIFICATIONS 18



CONTACT INFORMATION 19



WHAT DISPLAY SYMBOLS MEAN

Display Symbol	Condition/ Cause	Recommended Action
 MEASUREMENT IN PROGRESS	Appears during measurement; blinks when pulse is detected.	Remain still and refrain from talking; measurement in progress.
	Previous measurement stored in memory.	
 LOW BATTERY	Battery voltage is too low for monitor to work properly.	Replace all batteries with new ones.
	Appears if pressure value is unstable due to movement during reading.	Try measurement again and remain very still.
 CUFF ERROR	Air connector may not be placed properly into the unit. Cuff is not positioned properly on the arm.	Reinsert the air connector into the air socket.  MONITOR — CUFF HOSE Place cuff on arm properly (see page 7).
	Nothing appears in display.	Check batteries. Make sure batteries are properly installed.



MONITOR COMPONENTS

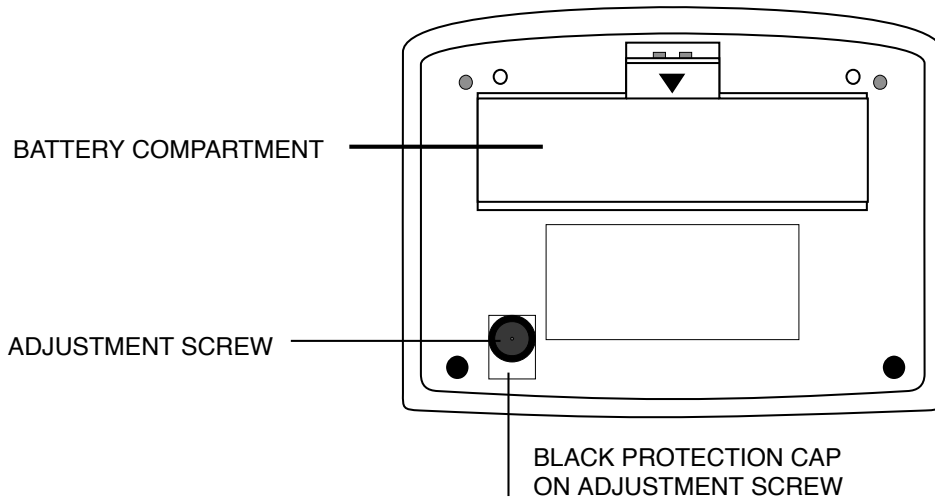
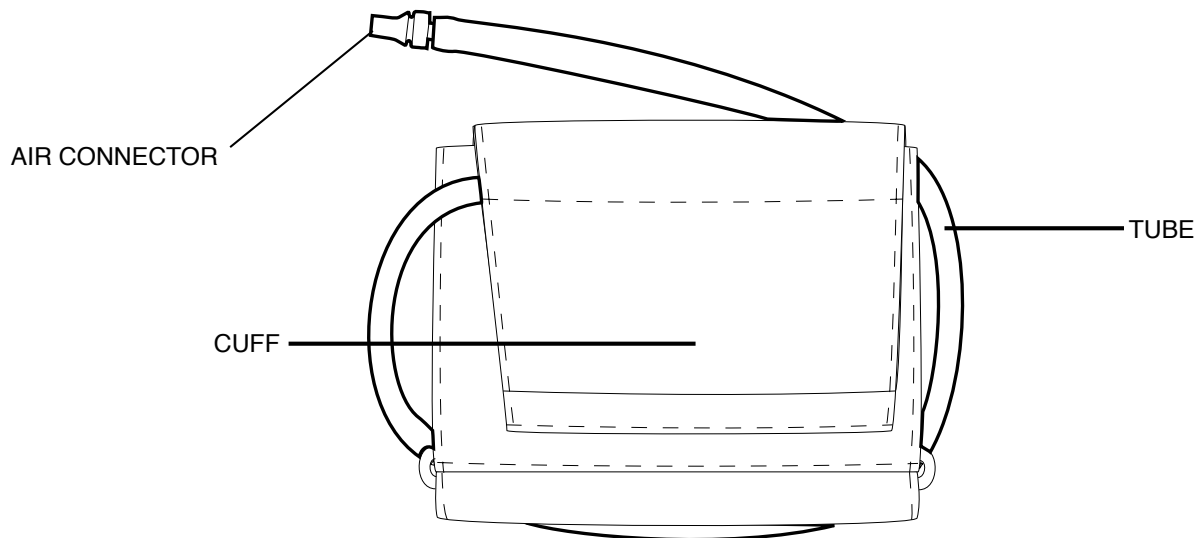
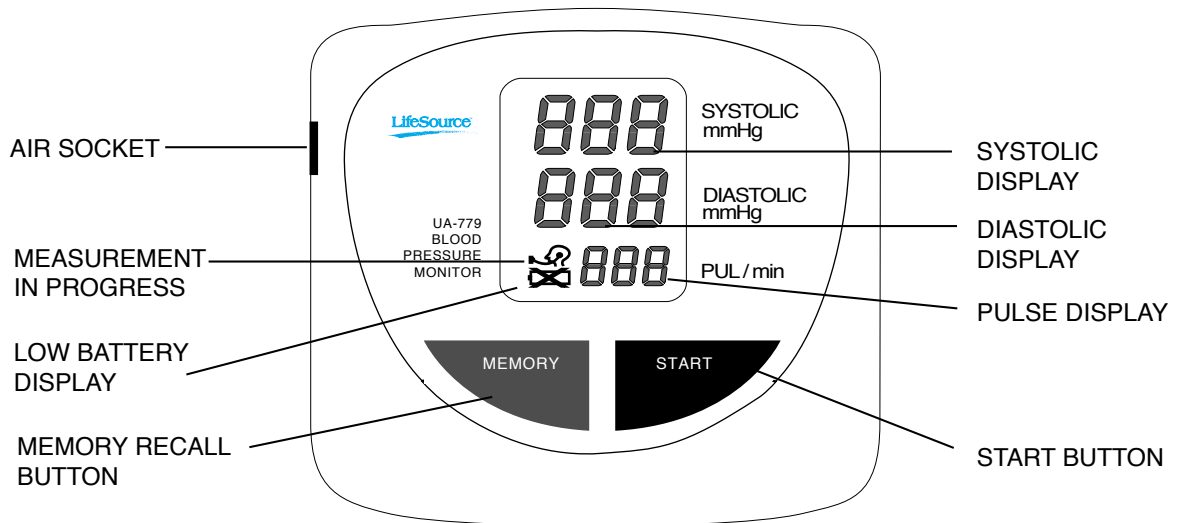



HOW 779 WORKS

LifeSource Blood Pressure Monitors are easy to use, accurate and digitally display full measurement readouts. Our technology is based on the “oscillometric method” — a noninvasive blood pressure determination. The term “oscillation” refers to any measure of vibrations caused by the arterial pulse. The cuff is first inflated until the artery is fully blocked. Then, the monitor takes measurements while the cuff deflates. Our monitors examine the pulsatile pressure generated by the arterial wall as it expands and contracts against the cuff with each heartbeat.

BEFORE YOU START



You must install 4 type AA (1.5 volt) batteries and attach the cuff to the monitor before using it. To install batteries (or replace them if the “Low Battery” symbol appears on display), proceed as follows:

1. Remove battery compartment cover by gently pushing down on arrow and sliding cover forward.
2. Put in top row of batteries first. Place the batteries in compartment with positive (+) and negative (–) terminals matching those indicated in the compartment. Be sure batteries make contact with compartment terminals.
3. Replace cover by sliding it into the compartment and gently pressing into place.

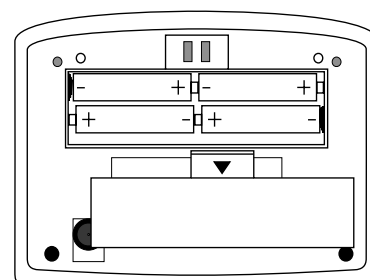
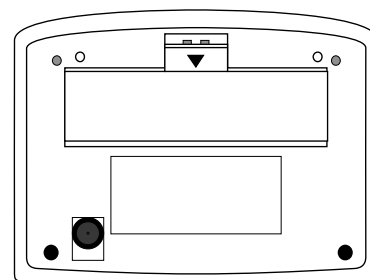

SELECTING THE CORRECT CUFF



Using the correct cuff size is important for an accurate reading. A cuff that is too large will produce a reading that is lower than the correct blood pressure; a cuff that is too small yields a measurement that is higher. With your arm hanging at the side of your body, measure the circumference of your upper arm at the midpoint between shoulder and elbow.

ARM SIZE	RECOMMENDED CUFF SIZE	REPLACEMENT CUFF MODEL#
5.1" - 7.9" (13-20cm)	Small	UA-279
7.5" - 12.2" (19-31cm)	Medium	UA-280
11.8" - 17.7" (30-45cm)	Large	UA-281

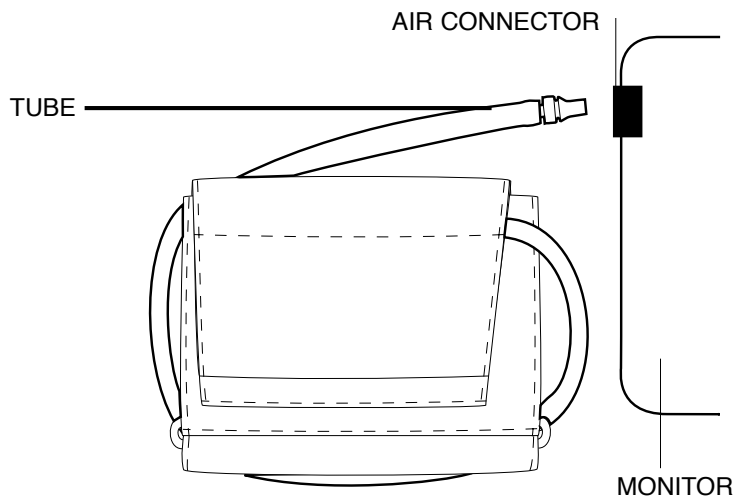

To attach cuff, insert air connector at end of cuff tube into air socket on left side of monitor. Should you need to change the cuff size, the preset exhaust velocity rate may have to be adjusted (see page 11).



TAKING YOUR BLOOD PRESSURE

Tips for Blood Pressure Monitoring:

- ☞ Relax for about 5 to 10 minutes before measurement.
- ☞ Remove constricting clothing and place cuff on bare arm.
- ☞ Unless your physician recommends otherwise, use left arm to measure pressure.

Now you are ready. Follow these simple steps:

1. Sit comfortably with your left arm resting on a flat surface so that the center of your upper arm is at the same height as your heart.
2. Lay left arm on the table, palm up and thread cuff end through metal loop, smooth side against arm. Then position the tube off-center toward the inner side of arm in line with the little finger.
3. Pull the end of the cuff to tighten it, fold back the extra material, and fasten securely. The cuff should be snug but not too tight. You should be able to insert two fingers between the cuff and your arm.

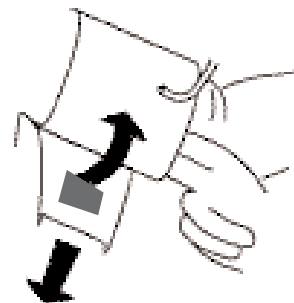
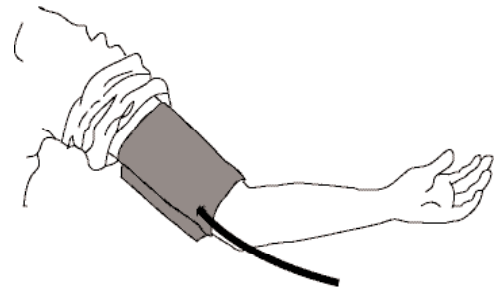
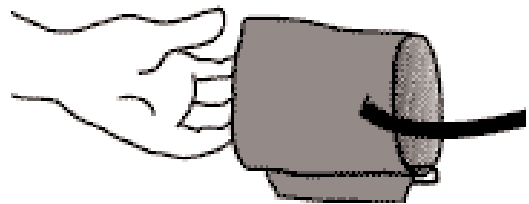

☞ **IMPORTANT:** Measure pressure at the same time each day.



TAKING YOUR BLOOD PRESSURE



4. Press the START button, remain still and do not talk as the cuff automatically inflates to the correct level.
5. If your systolic is higher than 250 mmHg you will need to hold down the START button to inflate the cuff to the proper level 40 mmHg over your usual systolic measurement. The maximum cuff pressure is set at 320 mmHg. If it reaches 320 mmHg, the auto exhaust will be triggered and cuff pressure will deflate to 0.
6. It is normal for the cuff to feel very tight. You will see all the display symbols appear briefly. As the cuff pressurizes, blinking numerals—starting at zero—are displayed. When inflation is complete, the MEASUREMENT IN PROGRESS symbol blinks and beeps with each pulse beat.

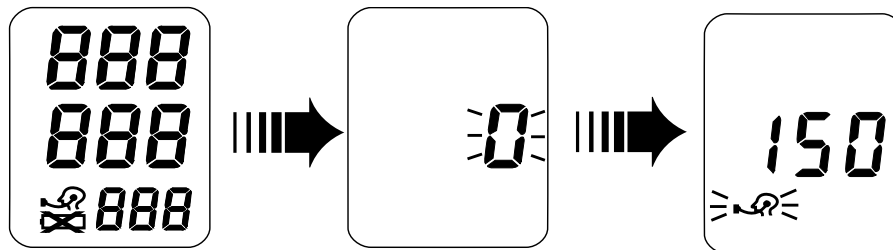

NOTE: If you wish to stop inflation at any time, press START button.



TAKING YOUR BLOOD PRESSURE

7. When measurement is complete, the systolic and diastolic pressure readings and pulse rate are displayed. The cuff deflates and the monitor shuts off after a few moments, or you can turn it off by pressing the START button.
8. Remove cuff and make a note of your blood pressure and pulse rate on the chart (see page 16), indicating date and time of measurement.

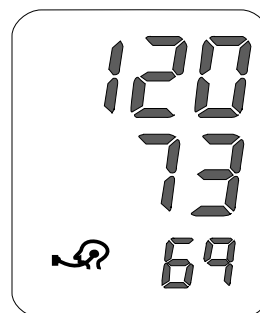

TAKING YOUR BLOOD PRESSURE



We advise that you record the date and time after each measurement because an accurate blood pressure history relies not on single or sporadic readings but on a pattern over time.

NOTE: If you wish to take your blood pressure again, relax and wait 5–10 minutes to enable the flow of blood in the arm to return to normal. There is no need to wait if someone else wishes to use the monitor.

ABOUT MEMORY

Advanced Inflation Sensor automatically stores up to seven blood pressure and pulse measurements in its memory.

To retrieve readings, follow these simple steps:

- 1.** With the monitor in “off” mode, press the MEMORY button. Your most recent measurement will appear on the display screen along with the **M** symbol.
- 2.** Press MEMORY once again to view each previous measurement committed to memory. The oldest reading is labeled “no. 1”.
- 3.** When a new reading is taken, the oldest reading will be eliminated from memory and the newest reading will be added.

NOTE: Memory data will be lost if batteries become low or are removed.



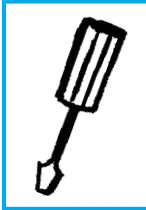

CHECK/ADJUST EXHAUST VELOCITY

Exhaust velocity is the rate at which the air pressure in the cuff deflates during the course of measurement. It is preset at the factory and generally does not need any further adjustment.

NOTE: The exhaust rate of your monitor was preset and tested at the factory to ensure proper measurement. The rate set is dependent on cuff size, not arm size. If using a cuff other than the one shipped with the unit, you may need to adjust the exhaust velocity rate. There is no need to adjust exhaust velocity when changing between a medium cuff and a large cuff with a valve.

To check the exhaust velocity rate, proceed as follows:

1. Put on the arm cuff.

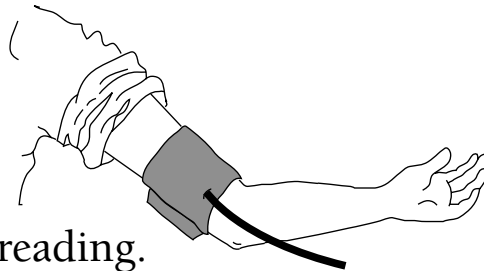

2. Press the START button.
The unit will begin taking a reading.

3. Watch the display screen as the cuff deflates. When the MEASUREMENT IN PROGRESS symbol appears, the numbers should decline in increments of 2 to 5 mmHg.

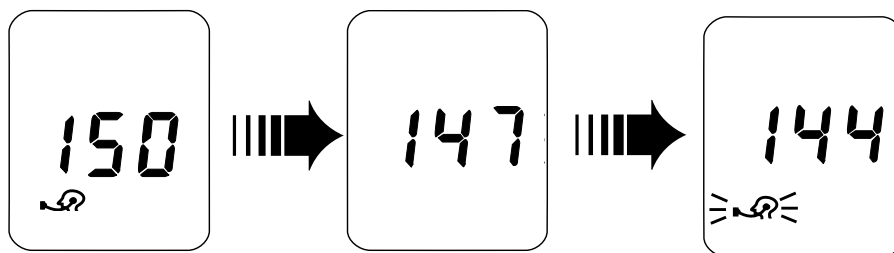

CHECK/ADJUST EXHAUST VELOCITY



If the exhaust velocity range is not within 2 to 5 mmHg, make the following adjustment with the unit turned off:

1. With the edge of your fingernail, peel off the thin black plastic disk covering the adjustment screw. If there is no thin plastic disk, proceed to step 2.

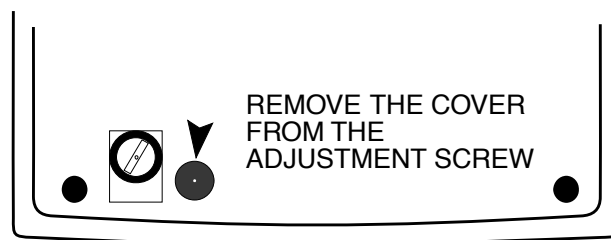

2. Using a small screwdriver, rotate adjustment screw about 45 degrees clockwise (to raise the rate) or counterclockwise (to lower the rate).

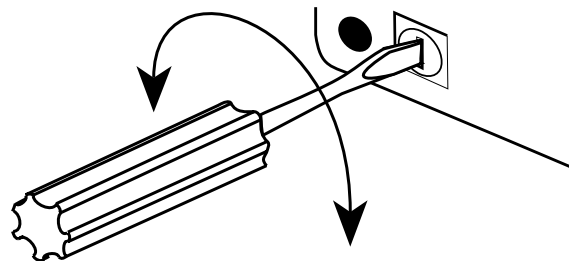

3. Repeat the test until the exhaust velocity is between 2 and 5 mmHg.

NOTE: Once the monitor is adjusted to a new cuff size, further adjustments should not be required unless cuff size is changed again.





ABOUT BLOOD PRESSURE

■ What Is Blood Pressure?

Blood pressure is the force exerted by blood against the walls of the arteries. Systolic pressure occurs when the heart contracts; diastolic pressure occurs when the heart expands. Blood pressure is measured in millimeters of mercury (mmHg).

■ What Affects Blood Pressure?

Blood pressure is affected by many factors: age, weight, time of day, activity level, climate, altitude and season. Certain activities can significantly alter blood pressure. Walking can raise systolic pressure by 12 mmHg and diastolic pressure by 5.5 mmHg. Sleeping can decrease systolic blood pressure by as much as 10 mmHg. Taking your blood pressure repeatedly without waiting an interval of at least 3 minutes between readings can also affect it.

In addition to these factors, beverages containing caffeine or alcohol, certain medications, emotional stress and even tight-fitting clothes can make a difference in the readings.

■ What Causes Variations In Blood Pressure?

An individual's blood pressure varies greatly from day to day and season to season. In hypersensitive individuals, these variations are even more pronounced. Normally, blood pressure rises during work or play and falls to its lowest levels during sleep.

Fluctuation within a day (case: 35 year old male)

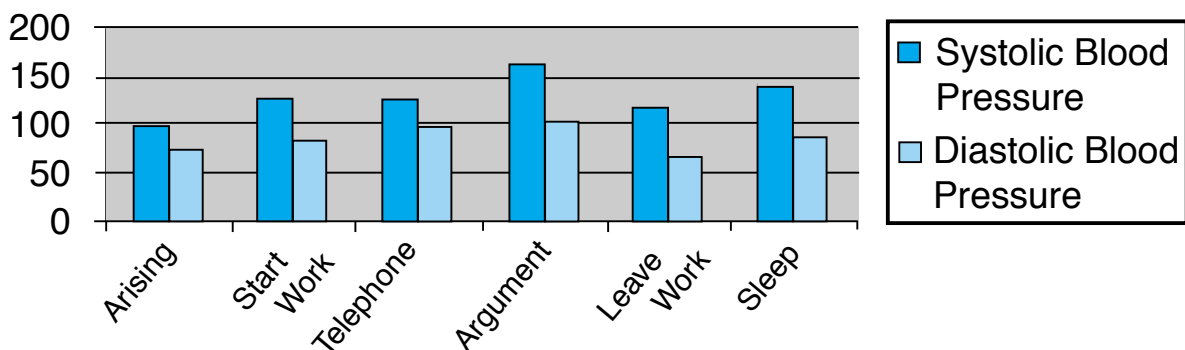

ABOUT BLOOD PRESSURE



■ Assessing High Blood Pressure

The following standards for assessing high blood pressure (without regard to age) have been established as a guideline.

BP Classification	Systolic (mmHg)		Diastolic (mmHg)
Normal	<120	and	<80
Prehypertension	120-139	or	80-89
Stage 1 Hypertension	140-159	or	90-99
Stage 2 Hypertension	≥160	or	≥100

SOURCE: The Seventh Report of the Joint National Committee on Prevention, Evaluation and Treatment of High Blood Pressure. National Heart, Lung and Blood Institute - May 2003.

■ What Is Hypertension?

Hypertension (high blood pressure) is the diagnosis given when readings consistently rise above normal. It is well known that hypertension can lead to stroke, heart attack or other illness if left untreated. Referred to as a “silent killer” because it does not always produce symptoms that alert you to the problem, hypertension is treatable when diagnosed early. Those who fall within the Prehypertensive range are more likely to develop hypertension in the future.

■ Can Hypertension Be Controlled?

In many individuals, hypertension can be controlled by altering lifestyle and minimizing stress, and by appropriate medication prescribed and monitored by your doctor. The American Heart Association recommends the following lifestyle suggestions to prevent or control hypertension:

- Don't smoke.
- Reduce salt and fat intake.
- Maintain proper weight.
- Exercise routinely.
- Have regular physical checkups.
- Monitor your blood pressure at periodic intervals.





ABOUT BLOOD PRESSURE

■ **Why Measure Blood Pressure at Home?**

It is now well known that, for many individuals, blood pressure readings taken in a doctor's office or hospital setting might be elevated as a result of apprehension and anxiety. This response is commonly called "white coat hypertension." One way to determine whether this is the case for you is to take your home monitor to the doctor's office and, before the doctor or nurse takes your pressure, do it yourself on your home monitor and compare it to your record of home readings.

In any case, self-measurement at home supplements your doctor's readings and provides a more accurate, complete blood pressure history. In addition, clinical studies have shown that the detection and treatment of hypertension is improved when patients both consult their physicians and monitor their own blood pressure at home.

■ **Keys to Successful Monitoring:**

Blood pressure fluctuates throughout the day. We recommend that you are consistent in your daily measurement routine:

- Measure at the same time every day.
- Sit in the same chair/position.
- Relax for 5 minutes before measurement.
- Sit still during measurement – no talking, eating or sudden movements.
- Record your measurement in a logbook.

■ **How Do I Record My Blood Pressure?**







Blood pressure readings are typically recorded with the systolic pressure written first, followed by a slash mark and the diastolic pressure. For example, 120 mmHg systolic and 80 mmHg diastolic measurements are written as 120/80. Pulse is simply written with the letter "P" followed by the pulse rate—P 72, for example. Please see Page 16 for the blood pressure record.





IMPORTANT INFORMATION

Please read this important information before using your monitor.

-  Please remember that only a medical practitioner is qualified to interpret your blood pressure measurements. Use of this device should not replace regular medical examinations.
-  Have your physician review your procedure for using this device. He or she will want to verify blood pressure measurements before prescribing or adjusting medications.
-  Consult your physician if you have any doubt about your readings. Should a mechanical problem occur, contact LifeSource.
-  Do not attempt to service, calibrate, or repair this device.
-  Because your UA-779 monitor contains delicate, high-precision parts, avoid exposing it to extremes in temperature or humidity or to direct sunlight, shock and dust. LifeSource guarantees the accuracy of this device only when it is stored and used within the temperature and humidity ranges noted on page 18.
-  Clean the monitor and cuff with a dry, soft cloth or a cloth dampened with water and a mild detergent. Never use alcohol, benzene, thinner or other harsh chemicals to clean monitor or cuff.
-  Remove and replace batteries if monitor is not used for more than **six months**.

PRECAUTIONS

UA-779 is designed to be used at home, by those who are eighteen (18) years and older, to monitor blood pressure (systolic and diastolic) and pulse rate. This monitor is not designed to measure the blood pressure of people with common arrhythmias, such as atrial or ventricular premature beats or atrial fibrillation. It is not designed for ambulatory use.



SPECIFICATIONS



Model	UA-779
Type	Oscillometric
Display	Digital, character height Pressure (15.5)/pulse (10mm) displayed simultaneously
Memory	7 readings
Measurement range	Pressure: 20 mmHg to 280 mmHg Pulse: 40 pulses to 200 pulses per minute
Accuracy	Pressure: ± 3 mmHg or 2%, whichever is greater Pulse: $\pm 5\%$
Pressurization	Automatic, using micropump
Depressurization	Automatic constant speed
Power source	4 type AA (1.5 volt) alkaline batteries (not included)
Battery life	Approximately 4 months with one daily measurement
Operating environment	50°F to 104°F (10°C to 40°C) Less than 85% relative humidity
Storage environment	-4°F to 158°F (-20°C to 70°C) Less than 95% relative humidity
Dimensions	Length: 4.9" (125 mm) Width: 5.6" (142 mm) Height: 2.9" (74 mm)
Weight	10.6 oz. (300 g) without batteries

Blood pressure measurements determined by the UA-779 are equivalent to those obtained by a trained observer using the cuff/stethoscope auscultation method within the limits prescribed by the American National Standards Institute for electronic or automated sphygmomanometers.





CONTACT INFORMATION

Our products are designed and manufactured using the latest scientific and technological methods, and offer accurate, easy to use, home monitoring and treatment options. Our full product line includes:

- **Aneroid Blood Pressure Kits**
- **Blood Pressure Cuffs**
- **Digital Blood Pressure Monitors**
- **Digital Thermometers**
- **Heart Rate Monitors**
- **Nebulizers**
- **Personal Health Scales**
- **Stethoscopes**

This *LifeSource* blood pressure product is covered by a Lifetime Warranty. See warranty card for details.

**Visit our web site at www.LifeSourceOnline.com
for warranty registration.**

For more information regarding use, care or servicing of your blood pressure monitor, contact:

A&D Medical
A division of A&D Engineering, Inc.
1555 McCandless Drive
Milpitas, CA 95035
LifeSource Health Line (Toll-Free): 1-888-726-9966
www.LifeSourceOnline.com

For Canada Residents, please contact:
Auto Control Medical
6695 Millcreek Drive, Unit 5
Mississauga, Ontario
L5N 5R8 Canada
Auto Control (Toll-Free): 1-800-463-5414
www.autocontrol.com



IMPORTANT!

If You Need Assistance with the Set-Up or Operation

We Can Help!

Please call us FIRST before contacting your retailer at

LifeSource Health Line

1-888-726-9966 - Toll Free

1-800-463-5414 - In Canada

A specially trained representative will assist you



A division of A&D Engineering, Inc.
1555 McCandless Drive
Milpitas, CA 95035
www.LifeSourceOnline.com

LifeSource is a trademark of A&D Medical.
©2003 A&D Medical. All rights reserved.
Specifications subject to change without notice.